



**Multi-Spectrum UV/Dual IR/VIS
Fire and Flame Detector**

Fire Sentry FS20X Detector



Features

- Patented* WideBand IR™ Infrared combined with Ultraviolet
- Detection range greater than 60 m (200 feet) to 0.1 m² (1 sq. ft.) heptane fire
- Patented* Electronic Frequency Analysis
- Visible sensor for optimum false alarm rejection
- Selectable detection sensitivities
- Solar blind 90° cone-of-vision
- Dual microprocessors for reliable performance
- Real-time clock for accurate time dating of events
- FirePic™ — Up to 6 pre-fire event data storage
- Event log — Up to 200 events with date and time stamp
- Built-in RS-485 ModBus communication
- Built-in non-isolated 4-20 mA analog output (sink or source)
- Alarm, Fault and Fire Verification relays
- Automatic Optical Path and Electronic self-test
- Patented* Electronics Module for component protection with plug-in terminations for easy field installation
- Two 25 mm conduit entries or two ¾" NPT
- Low power consumption
- High RFI and EMI immunity
- FM hazardous area approved
- Ex d ATEX approved
- CU-TR approved
- INMETRO approved
- Meets SIL 2 requirements
- Certified to EN54-10:2002 (option)
- FM 3260 performance

Benefits

- Detects hydrocarbon and non-hydrocarbon fuel fires in all environmental conditions
- Wide operating temperature range
- Arc welding immunity
- False alarm rejection
- Minimal maintenance for trouble-free operation
- PC software and interface module (FSIM) for fault diagnostics real-time graphs (RTGs), and downloading of FirePics™ and event log
- Suitable for a wide variety of applications

Applications

- Refineries and oil production facilities
- Off-Shore platforms
- Turbine/Compressor enclosures
- Acetylene processing and storage
- Oil and Gas pipelines and pumping stations
- LNG/LPG loading and unloading facilities
- Natural Gas and CNG plants
- Ethanol, Methanol, and IPA production and storage
- Crude oil and gasoline storage and tank farms
- Aircraft hangars
- Hydrogen plants and storage
- Paint and solvent storage
- Chemical production, storage, and loading facilities
- Power plants
- Silane gas storage

The Fire Sentry FS20X is the latest generation high technology Multi-Spectrum (UV/Dual IR/VIS) Fire and Flame Detector, which is part of the FSX family of advanced technology Electro-Optical Flame detectors.



Based on the foundation of the highly successful and reliable Fire Sentry SS4 detector, the Fire Sentry FS20X detector represents a quantum leap in integrating Infrared and Ultraviolet sensing technologies. The Fire Sentry FS20X is a Multi-Spectrum and UV/Dual IR/VIS fire and flame detector with a proven UV solar-blind sensor. The Fire Sentry FS20X exhibits faster false-alarm free response to fires over a wider temperature range and with a much longer detection range compared to conventional UV/IR detectors.

Conventional and older technology UV/IR detectors, using narrow band 4.3 micron IR sensors, will not respond to smoky fires or if the detector lens is contaminated with oil and other substances since both UV and 4.3 micron signals are attenuated, obscured or absorbed by thick smoke or detector lens contaminations. All UV sensors will be attenuated to some degree. Also, these old technology UV/IR detectors will not alarm to any fire if they are installed behind ordinary window glass.

The Fire Sentry FS20X detector using advanced patented algorithms for signal processing and fire and flame analysis is designed to alarm to all types of fires in all

industrial environmental conditions. If the detector's UV signal is degraded due to heavy smoke or a contaminated lens, the Fire Sentry FS20X's patented* WideBand IR™, Near Band IR and Visible sensors will still alarm to fire, albeit at a reduced sensitivity and slower response time.

Dual microprocessors provide a high level of fail-safe operation combined with fast and reliable performance. The master microprocessor performs high-speed digital sampling and signal processing calculations whilst the slave microprocessor handles various sensor data, performs communications, self-diagnostics and provides interface versatility and additional memory for storing event log and FirePic™ data.

The Fire Sentry FS20X detector has a detection range in excess of 60 m (200 feet) (very high sensitivity setting) for the detection of a 0.1m² (one square-foot) Heptane reference fire and has a cone of vision greater in volumetric coverage than most UV/IR detectors. This means fewer detectors can be used as compared to other manufacturers' detectors.

General Specification



General Specifications	
Field of view	90° Horizontal Cone of vision, ± 45° from on axis
Sensitivity	Very high (60m), high (45m), medium (30m) and low (15m) - switch selectable
Response time	3-5 Seconds to 0.1 m ² (1 sq. ft.) n-Heptane fire at 30 m (100 ft.) 3-10 Seconds to 0.1 m ² (1 sq. ft.) n-Heptane fire at 60 m (200 ft.)
Spectral sensitivity	Ultraviolet: 185 - 260 nanometres Visible: 400 – 700 nanometres Near Band IR: 0.7 – 1.1 microns Wide Band IR: 1.1 – 3.5 microns
Operating voltage	24 Vdc nominal (18-32 Vdc) - regulated
Power consumption	Operating: 85 mA @ 24 Vdc nominal
Alarm	135 mA @ 24 Vdc nominal
Heater	155 mA – additional Note: Heater will turn on at -17°C (0°F)
Output relays	Fire Alarm: SPDT (NO / NC) – De-energised/energised, latching/non-latching Fault: SPST (NO) – De-energised/energised, latching/non-latching Auxiliary: SPDT (NO / NC) – De-energised/energised, latching/non-latching Contacts rating: 1 amp @ 24 Vdc
Analog output	0 - 20 mA stepped - source or sink user selectable
Loop resistance	50 - 400 Ohms
Communication	One of the following – user selectable: <ul style="list-style-type: none"> • RS-485, ModBus Protocol • RS-485, FireBus II • RS-485 Special (optional) • HART, Optional plug-in module (not available on EN54-10 units)
Visual indications	Green LED: Power Red LED: Alarm Yellow LED: Fault
Temperature range	Operating: -40 to +85°C (-40 to +185°F) Storage: -55 to +110°C (-67 to +230°F)
Humidity range	5 to 98% relative humidity, non-condensing
Vibration	Meets or exceeds MilSpec 810C Method 514.2, Curve AW12
Wiring	2.5 mm ² (14 AWG) to 0.326 mm ² (22 AWG); shielded cable recommended
Conduit entries	Standard: Two M25 or two ¾" NPT
Enclosure materials	Copper-free powder coated aluminum or 316 stainless steel
Enclosure type	4X, IP66 and NEMA 4
Certifications	<p>FM: Class I, Div. 1 & 2, Groups B, C, & D; Class II, Div. 1 & 2, Groups E, F, & G; Class III</p> <p>ATEX/IECEx: II 2 G Ex db IIC T4 (Ta: -40 to +110°C), T5 (Ta: -40 to +75°C), T6 (Ta: -60 to +60°C), II 2 D Ex tb IIIC T135°C II 2 G Ex db IIC T4 (Ta: -60 to +110°C), T5 (Ta: -60 to +75°C), T6 (Ta: -60 to +60°C), II 2 D Ex tb IIIC T135°C</p> <p>CE: Complies with EN6100-6-4 & EN50130-4</p> <p>INMETRO</p> <p>CU-TR</p> <p>SIL Rating: FMEDA available on request</p> <p>EN54-10: FS20X certified 1175a/01 (LPCB); CPR 0832-CPR-F0515</p>
Shipping weight	Aluminum: 1.6 kg (3.6 lbs) Stainless Steel: 3.2 kg (7 lbs)
Mounting	Swivel bracket assembly - optional
Warranty	Three years from date of shipping

General Dimensions
Side and Back Views
(All Dimensions in mm)

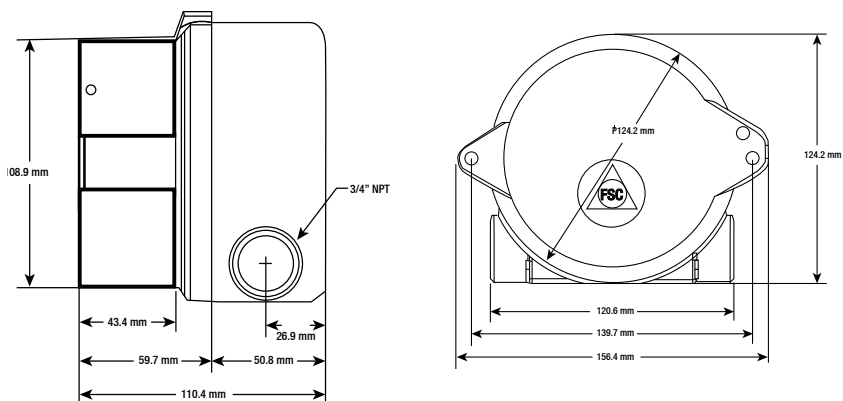

Honeywell Analytics Gas Detection



Honeywell Analytics is able to provide gas detection solutions to meet the requirements of all applications and industries. Contact us in the following ways:

Headquarters

Europe, Middle East, Africa

Life Safety Distribution AG

Javastrasse 2

8604 Hegnau

Switzerland

Tel: +41 (0)44 943 4300

Fax: +41 (0)44 943 4398

gasdetection@honeywell.com

Customer Service:

Tel: 00800 333 222 44 (Freephone number)

Tel: +41 44 943 4380 (Alternative number)

Fax: 00800 333 222 55

Middle East Tel: +971 4 450 5800 (Fixed Gas Detection)

Middle East Tel: +971 4 450 5852 (Portable Gas Detection)

Americas

Honeywell Analytics Distribution Inc.

405 Barclay Blvd.

Lincolnshire, IL 60069

USA

Tel: +1 847 955 8200

Toll free: +1 800 538 0363

Fax: +1 847 955 8210

detectgas@honeywell.com

Asia Pacific

Honeywell Analytics

Asia Pacific

#701 Kolon Science Valley (1)

43 Digital-Ro 34-Gil, Guro-Gu

Seoul 152-729

Korea

Tel: +82 (0) 2 6909 0300

Fax: +82 (0) 2 2025 0388

India Tel: +91 124 4752700

analytics.ap@honeywell.com

Technical Support Centres

Honeywell Analytics Ltd.

4 Stinsford Road

Nuffield Industrial Estate

Poole, Dorset, BH17 0RZ

United Kingdom

Tel: +44 (0) 1202 645 544

Fax: +44 (0) 1202 645 555

Honeywell Analytics

ZAC Athélia 4 - 375 avenue du Mistral

Bât B, Espace Mistral

13600 La Ciotat

France

Tel: +33 (0) 4 42 98 17 75

Fax: +33 (0) 4 42 71 97 05

Honeywell Analytics

Elsenheimerstrasse 43

80687 München

Germany

Tel: +49 89 791 92 20

Fax: +49 89 791 92 43

Honeywell Analytics

P.O. Box-45595

6th Street

Musaffah Industrial Area

Abu Dhabi

UAE

Tel: +971 2 554 6672

Fax: +971 2 554 6672

EMEA: HAexpert@honeywell.com

US: ha.us.service@honeywell.com

AP: ha.ap.service@honeywell.com

www.honeywellanalytics.com

www.raesystems.com

Honeywell Analytics
Experts in Gas Detection

BWF
Technologies
by Honeywell

RAE
SYSTEMS
by Honeywell

Please Note:

While every effort has been made to ensure accuracy in this publication, no responsibility can be accepted for errors or omissions. Data may change, as well as legislation, and you are strongly advised to obtain copies of the most recently issued regulations, standards, and guidelines. This publication is not intended to form the basis of a contract.

12984_H_Fire Sentry_FS20X_DS01125_V4_EMEA

06/15

© 2015 Honeywell Analytics

Honeywell